

3500/06 Weatherproof Housing

Bently Nevada* Asset Condition Monitoring

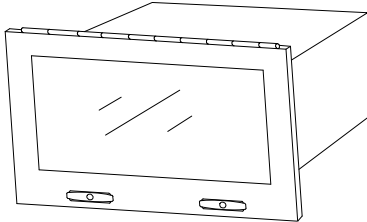

Description

The Bently Nevada 3500/06 Weatherproof Housing protects the 3500 System against adverse environmental conditions, such as excessive moisture, dirt, grime, and unclean air. An optional purging system protects the rack from outside elements.

The housing is specially designed for system installations that require environmental protection or where safety standards mandate air purging to meet approval agency requirements. The weatherproof housing is available in either epoxy-coated steel or 304 stainless steel and is compatible with a full-size rack (rack mount), mini-rack (rack mount), and internal barrier I/O modules.

When using the weatherproof housing, you should take precautions to avoid operating the monitors above their temperature specifications. Due to the heat dissipated by the 3500 monitoring system, you should not use the weatherproof housing in direct sunlight.

Application Alert
Exceeding the specified operating temperature of the 3500 system may degrade the reliability of the monitoring system and potentially ignite some gases.

Specifications

Housing Weight

22.7 kg (50 lb.).

Additional Weight

Conduit Fitting Option -01

454 g (1 lb.)

Air Purge Option -01

1.81 kg (4 lb.)

Air Purge Option -02

3.18 kg (7 lb.)

Ordering Information

3500/06 -AXX -BXX -CXX

A: Housing / Door Material

- 01 Epoxy-coated steel housing (full size rack)
- 02 Stainless steel housing (full size rack)
- 03 Epoxy-coated steel door only (full size rack)
- 04 Stainless steel door only (full size rack)
- 05 Epoxy-coated steel door only (Mini-rack)
- 06 Stainless steel door only (Mini-rack)
- 07 Epoxy-coated steel housing (Mini-rack)
- 08 Stainless steel housing (Mini-rack)

B: Conduit Fitting Option

- 00 Not required
- 01 Required. Includes four 1 1/4-inch NPT weatherproof hubs

C: Air Purge

- 00 No air purge accessories required
- 01 Air purge fitting used with Conduit Fitting Option -01. Includes four 1-1/4-inch NPT poured seal-type fittings and one 1/4-inch NPT weatherproof hub with fitting to reduce down to 1/4-inch NPT (female) for air input.
- 02 Air purge fittings and gauge; must be used with Conduit Fitting Option -01. Includes purge fittings supplied with Option -01, gauge assembly, bulkhead connector, and connecting tube.

D: Agency Approval Option

- 00 None
-

Spares

129766-01

Rack Installation and Maintenance Manual

Graphs and Figures

Table 1 and Table 2 are air purge specifications for the 3500/06 weatherproof housing

Table 1: N.F.P.A. 496 5X Air Purge Specification

Use this table for 5X purge per N.F.P.A. 496		
Pressure (in. of water)	Flow through air purge pipe (cu. ft./minute)	Time for purging weatherproof housing (minutes)
0.2	0.33	46
0.4	0.67	23
0.6	0.83	19
0.8	1.00	16
1.0	1.08	14
1.5	1.25	12
2.0	1.42	11
2.5	1.57	10
3.0	1.72	9
3.5	1.85	8
4.0	2.00	8
4.5	2.11	8
5.0	2.22	7
5.5	2.33	7
6.0	2.42	7
6.5	2.50	6
7.0	2.59	6
7.5	2.67	6
8.0	2.74	6
8.5	2.80	6
9.0	2.87	6
9.5	2.93	6
10.0	3.00	5

Table 2: Canadian Electrical Code C22.1, Part 1 Air Purge Specification

Use this table for 10x purge per Canadian Electrical Code C22.1, Part 1				
Pressure		Flow through air purge pipe		Time for purging weatherproof housing
in. of water	kPa	cu. ft./min.	m ³ /hour	minutes
1.0	0.25	1.08	1.83	14
1.5	0.37	1.25	2.12	12
2.0	0.50	1.42	2.42	11
2.5	0.62	1.57	2.67	10
3.0	0.75	1.72	2.92	9
3.5	0.87	1.85	3.14	8
4.0	1.00	2.00	3.40	8
4.5	1.12	2.11	3.58	8
5.0	1.25	2.22	3.77	7
5.5	1.37	2.33	3.96	7
6.0	1.50	2.42	4.11	7
6.5	1.62	2.50	4.25	6
7.0	1.74	2.59	4.40	6
7.5	1.87	2.67	4.54	6
8.0	1.99	2.74	4.66	6
8.5	2.12	2.80	4.76	6
9.0	2.24	2.87	4.88	6
9.5	2.37	2.93	4.98	6
10.0	2.49	3.00	5.10	5

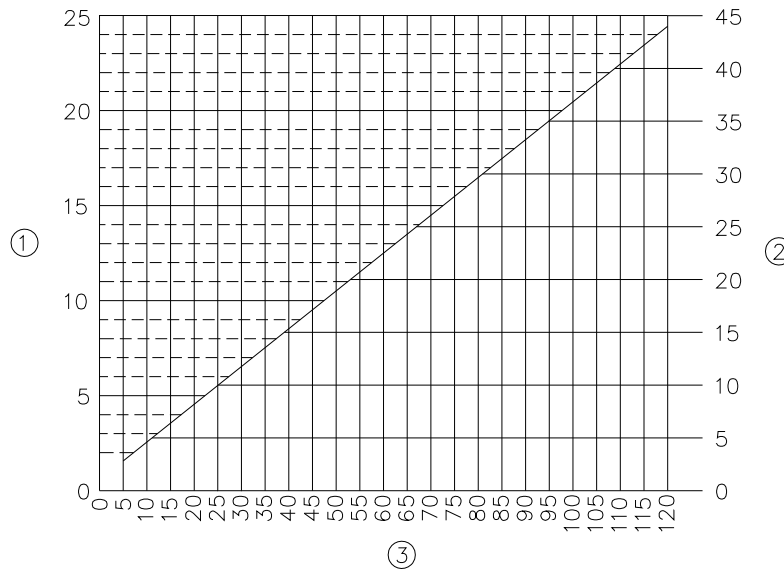

- 1) Temperature Rise above ambient, degrees C.
- 2) Temperature Rise above ambient, degrees F.
- 3) Power dissipated in Watts.

Figure 1: Rack Temperature Derating Graph

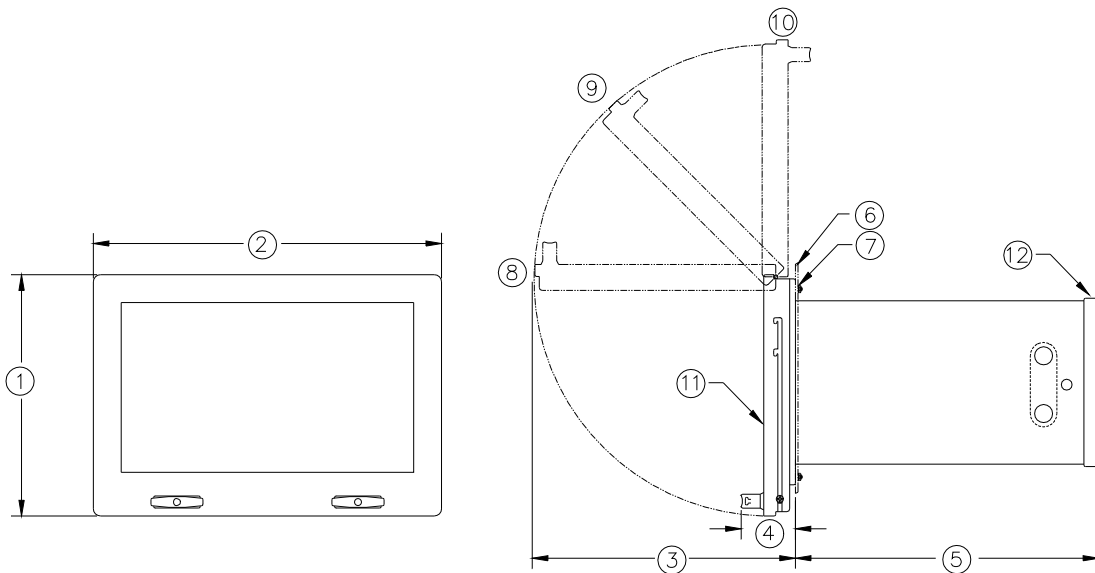

- | | |
|---|---|
| <ul style="list-style-type: none"> 1) 16.70 inches (424.2 mm). 2) 23.43 inches (595.1 mm). (full size rack)
16.43 inches (417.3 mm). (mini-rack) 3) 16.20 inches (411.5 mm). 4) 3.75 inches (95.3 mm). 5) 21.00 inches (533.4 mm). 6) Panel to which the housing is mounted. 7) Thread-seal washers supplied with the housing. To be used under all internal heads of mounting bolts or nuts to obtain a water-tight seal. | <ul style="list-style-type: none"> 8) The housing door will latch in this 90 degree position. 9) The housing door will latch in this 135 degree position. 10) The door must be opened to this position to latch or unlatch the door in the two shown latching positions. 11) Hinged door for access to front of rack. 12) Bolted cover for access to rear of rack. |
|---|---|

Figure 2: Weather-Proof Housing Mechanical Specifications

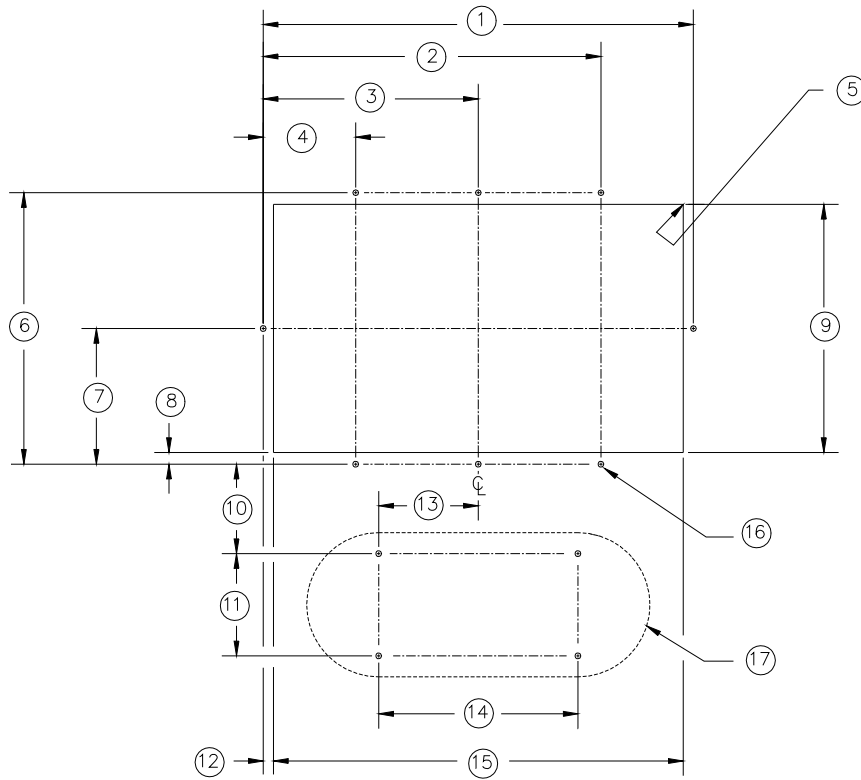

- | | |
|---|--|
| 1) 21.050 inches (534.7 mm). (full size rack)
14.050 inches (356.87 mm). (mini rack) | 12) 0.50 inches (12.7 mm). |
| 2) 16.525 inches (419.7 mm). (full size rack)
11.525 inches (292.74 mm). (mini rack) | 13) 4.87 inches (123.7 mm). |
| 3) 10.525 inches (267.3 mm). (full size rack)
7.025 inches (178.44 mm). (mini rack) | 14) 9.75 inches (247.7 mm). |
| 4) 4.525 inches (114.9 mm). (full size rack)
2.525 inches (64.135 mm). (mini rack) | 15) 20.05 inches (509.3 mm). (full size rack)
13.05 inches (331.47 mm). (mini rack) |
| 5) 0.25 inches (6.4 mm) radius, maximum (4 places). | 16) 0.281 inches (7.14 mm) diameter clearance hole for 0.250 inches diameter bolt or mounting studs. 8 places for housing. 12 places for housing and air purge gauge assembly. |
| 6) 13.27 inches (337.1 mm). | 17) This 4-hole pattern is only used when installing the air purge gauge assembly. |
| 7) 6.635 inches (168.5 mm). | |
| 8) 0.57 inches (14.5 mm). | |
| 9) 12.13 +/- 0.06 inches (308.1 +/- 0.2 mm). | |
| 10) 4.37 inches (111.0 mm). | |
| 11) 5.00 inches (127.0 mm). | |

Dimensions are +/- 0.02 inches (+/- 0.51 mm) unless specified otherwise.

Figure 3: Panel Cutout Dimensions

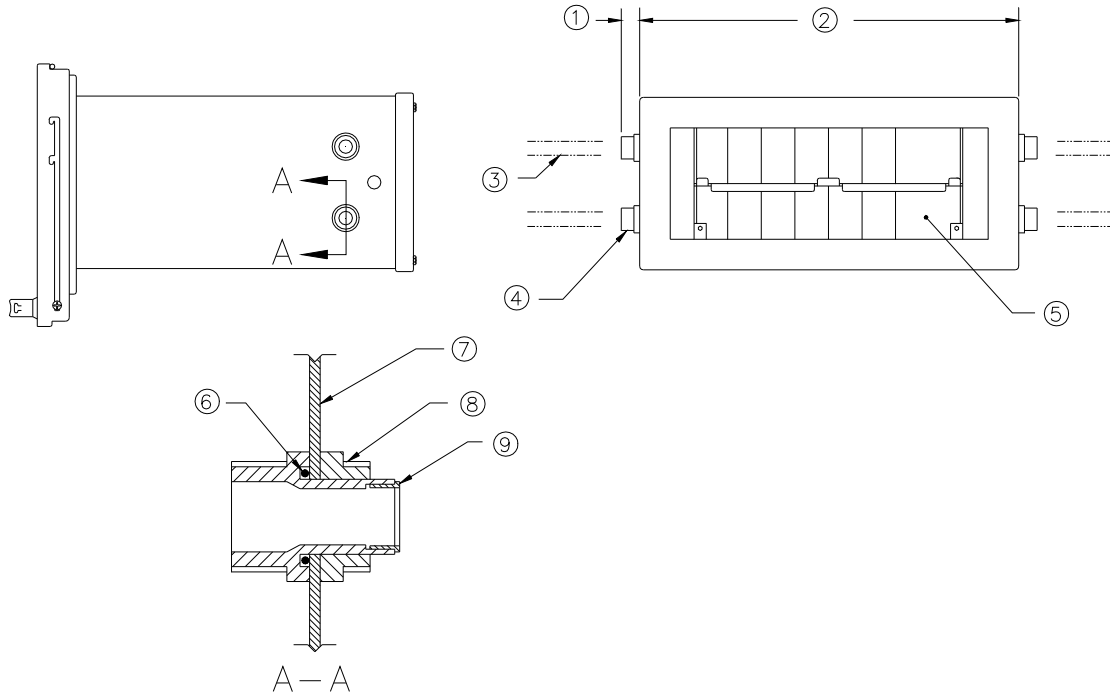

- 1) 1.03 inches (26.2 mm), 4 places.
- 2) 19.55 inches (496.6 mm). (full size rack)
- 3) 12.55 inches (318.77 mm). (mini rack)
- 4) Customer-supplied conduit, 4 places.
- 5) Weatherproof conduit hub. Also shown in cross-section A-A.
- 6) Rear view of housing with rear cover and typical 3500 rack installed.
- 7) "O"-ring seal.
- 8) Housing wall. Arrow points to inside surface of the housing.
- 9) Lock ring.
- 10) Collar.

Figure 4: Dimensions for side view, and Weatherproof Housing with Conduit Option.

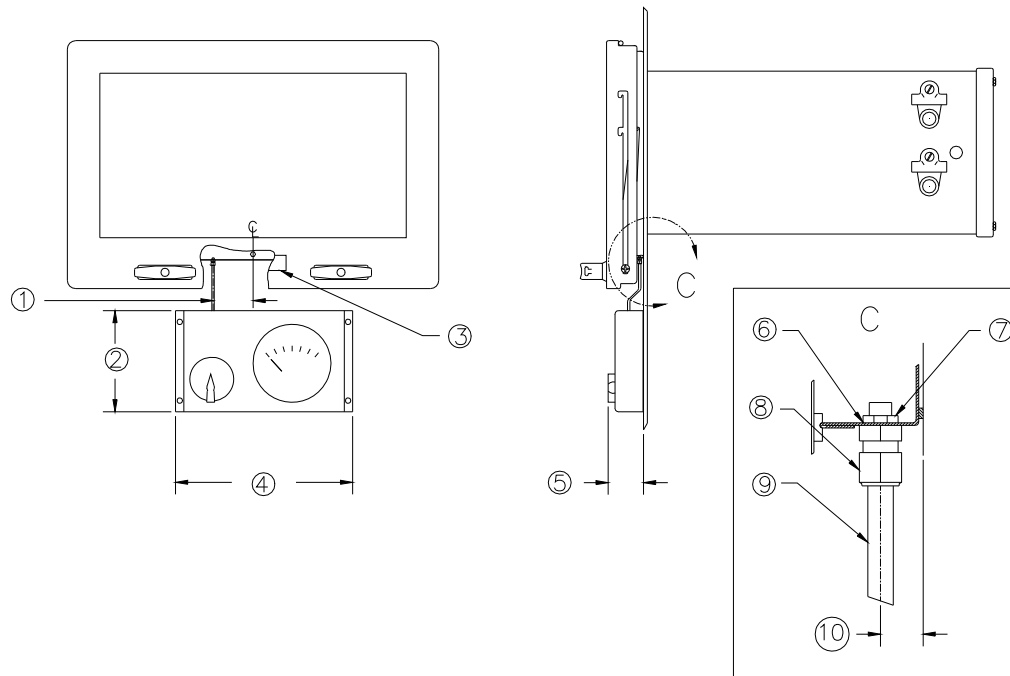

1. 3.00 inches (76.2 mm).
2. 6.00 inches (152.4 mm).
3. Purge warning label.
4. 10.50 inches (266.7 mm).
5. 3.25 inches (88.6 mm).
6. Drill a 0.43 inches diameter mounting hole.
7. Locknut.
8. Bulkhead fitting.
9. Connecting tube.
10. 0.50 inches (12.7 mm).

Figure 5: Weatherproof Housing with Purge fittings and gauge installation.

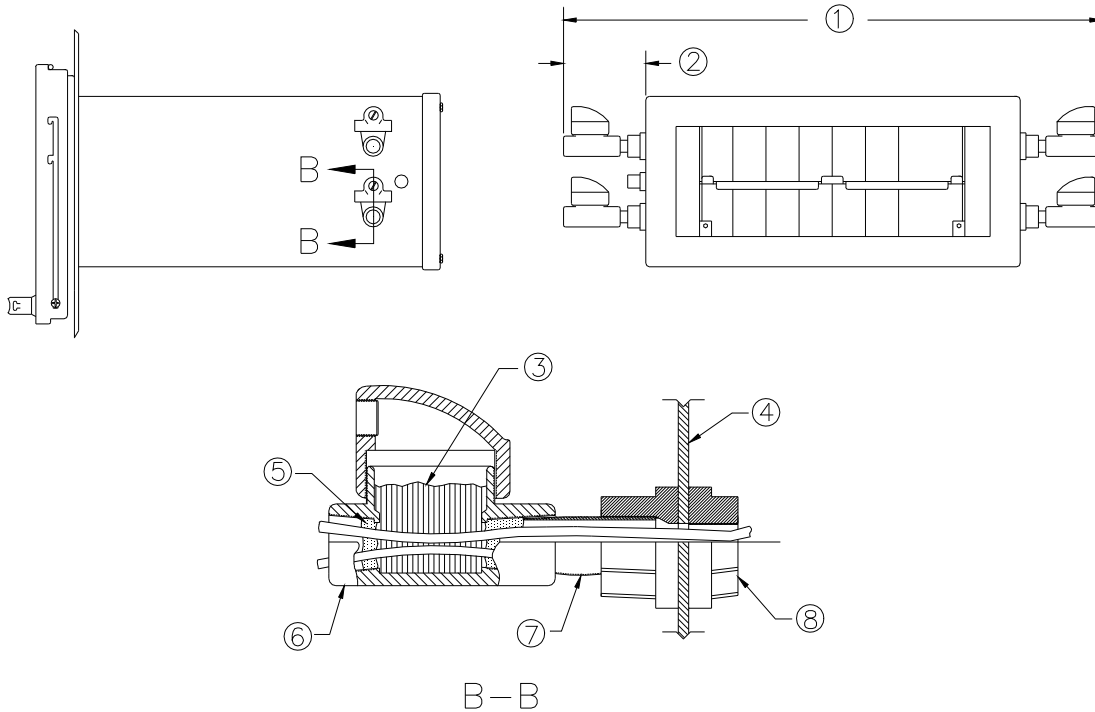

- 1) 31.05 inches (788.7 mm). (full size)
24.05 inches (610.87 mm). (mini rack)
- 2) 5.75 inches (146.1 mm).
- 3) Sealing compound.
- 4) Weatherproof housing wall, inside surface.
- 5) Packing fiber, 2 places.
- 6) Pour seal fitting.
- 7) Adapter.
- 8) Conduit hub.

Figure 6: Weatherproof Housing with Purge fittings and gauge installation (Continued).

Note: All wiring is routed through conduits mounted to the Weatherproof Housings. Both upper conduits are for transducer power, signal input, and recorder output wiring. Both lower conduits are for power input and relay wiring which should not be mixed in the same conduit with transducer, signal, and recorder wiring.

The Static Purge Pressure (Pressure required to insure that a Hazardous atmosphere does not enter the housing), must exceed 50.8 mm (2.0 in) of water. This is measured on the gauge (after the housing has been purged), with the valve in the closed position.

All test and recommendations made by Bently Nevada LLC are in accordance with specifications and requirements made by National Fire Prevention Agency in pamphlet 496 for Type "Y" purge, or Canadian Electrical Code: C 221.1, Part 1. For additional information on purge requirements refer to above standards.

* denotes trademarks of Bently Nevada, LLC, a wholly owned subsidiary of General Electric Company.

© 1999 – 2009 Bently Nevada LLC. All rights reserved.

1631 Bently Parkway South, Minden, Nevada USA 89423
 Phone: 775.782.3611 Fax: 775.215.2873
www.ge-energy.com/bently